

# Passive cooling for complex buildings in a humid tropical area- Study case Colombia

Agustin Adarve G Arch

Professional consultant, Adarve Arq, Bogota, Colombia

**ABSTRACT:** The presented case study relates to a naturally ventilated complex commercial building located in Colombia. The goals of this project are: a balanced integration between architectural features, bioclimatic requirements, cost-benefice relations and constructive needs. The strategies involved are: 1) The use of a combined stack and horizontal flow pattern in order to produce a high level of heat release at maximum interior air speeds. 2) The integration of a double envelope hollow brick façade to promote an effective solar control and radiant gains trough the interior building. The use of 14 solar towers help to exhaust heat, avoiding heat transfer to the internal concrete structure, producing an effective control of the thermal inertia. 3) The improvement of shading devices to avoid that direct solar gains go into open spaces (commercial main malls, meal spaces etc.) 4) The use of adequate insulating materials specially on the roof, in order to decrease interior temperatures due to solar radiation transfer at mid day.

To achieve the requirements, some creative or “innovative” strategies were designed: These strategies include the use of “ventilated sky lights” (operating as wind towers) at the top of the roof, combined to a fresh air exchanger at the basement, to increase the temperature difference.

Keywords: natural cooling, tropical architecture, comfort

## 1. INTRODUCTION

In Colombia, as in many tropical countries, passive cooling for complex buildings needs to be carefully integrated to the architecture if we want to solve comfort needs into an economical, technical and aesthetical way.

The commercial building Unicentro- Villavicencio is an example in the improvement of different cooling devises able to allow thermal comfort.

This paper presents the bioclimatic strategies, cooling results, conclusions and recommendations to take into account for a similar design process in developing countries located in humid tropical areas. The strategies that were used take special care of the local climate factors regard comfort stress, building specific needs, such as ventilation openings, solar and thermal control devises.

After monitoring the core building, the results shows some conclusions to be discussed forward:

- Vertical air flow is essential to assure effective air movement, if the height of the open atrium produces a good heat stratification.
- The convection flows produced by a good stratification have a better performance if ventilated sky lights are placed directly in the top of the mall atrium.
- When there are no sky lights, a good insulated and reflective roof produces expected results.

- Double facade walls are essential to control mass inertia, so that the interior walls temperatures remain lower.

The adopted cooling strategies guarantee structure and insulation economies, because it does not represent additional building costs.

In addition, ventilated sky lights offer natural day lighting.

## 2. CLIMATIC ANALYSIS

### 2.1 Climate type

Villavicencio is a provincial capital located at 4 °N latitude, on the eastern planes between Colombia and Venezuela. It represents a typical hot humid area with external temperatures and humidity pattern away from de comfort zone during the day.

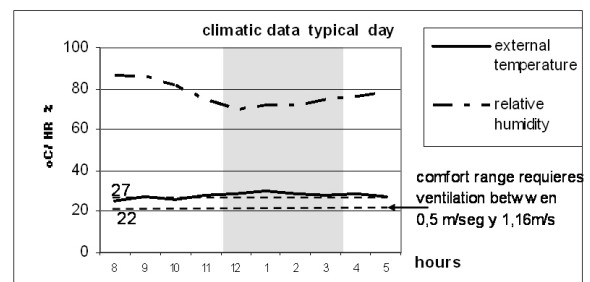

**Figure 1:** climatic data- over heated period (grey). R.M Aynsley [1] adjusts the comfort zone range between 24 °C – 30 °C at latitudes less than 30 °.

To create adequate conditions under high humidity levels, external temperatures requires to be decreased, and to be promoted internal air flow. Also the thermal inertia needs to be controlled specially during the afternoon.

### 3. BIOCLIMATIC STRATEGIES

#### 3.1 Architectural Layout.

The entire building has 50.000 m<sup>2</sup> distributed into three commercial levels, and two underground parking areas. The pedestrian corridors, plazas and café terraces are designed to be naturally cooled. Shops are supposed to solve their comfort needs using mechanical or air conditioned systems.

The commercial levels are connected vertically by open atriums, which include stairways and elevators. The centre is oriented east-west according to the urban and plot conditions.

#### 3.2 Bioclimatic features:

- In order to promote internal air flow, the building takes external air directly from open main entrances and open facades placed at café terraces (oriented facing to prevailing S.W winds). Additional air supply comes from underground pipes, using a vacuum pump to pull down air from the street level and releasing it at the bottom level - 1<sup>st</sup> floor.
- In the other hand, four high atrium areas make possible a high stratification of internal air mass.
- The curved roof and the wind skylights, promote the stack effect and heat release by convection forces.
- To control direct solar radiation coming from the west during the afternoon, were designed suspended metallic sunshades which are placed above the entrances. Also there are close exterior walls without openings.
- To control heat transmission trough the envelope, a double naturally ventilated hollow brick façade was created. To prevent direct heat gains by horizontal solar radiation at noon, there is a roof composed with double white metallic sheet ( sandwich deck) using as insulation a 5cm of mineral wool

The above strategies are illustrated in figure 2.

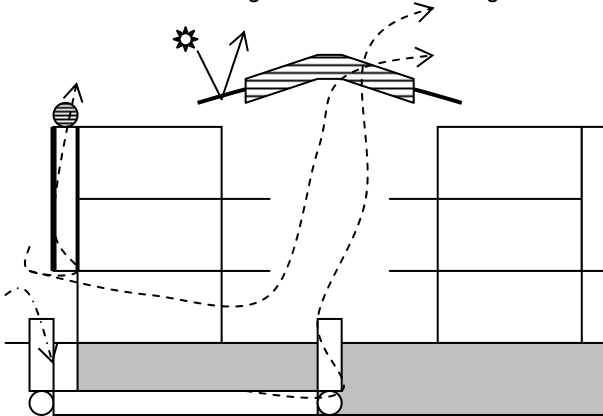

Figure 2: Ventilation strategies - Section view



Figure 3: North- west main facades

### 4. COOLING RESULTS

Actually the entire core structure has been finished, including the external and internal walls, floors and the roof. Finishing details as solar shading devises, underground pipes, and sky roof ventilation blades will be installed during May 2006. Nevertheless, preliminary test results show the efficiency of the envelope and its internal main spaces as the atria, corridors and double facade space.

The monitoring process was carried out during a special hot and humid day of March 2006. The monitoring tests focused on three cooling results:

- The effect of atria and ventilated sky lights on internal air stratification levels.
- The combined effect of ventilated sky lights and insulated roof in the diminution of maximum external temperatures.
- The effect of the naturally ventilated double facade in the radiant internal temperatures

The figure No 4 shows the internal profile of humidity, indoor temperatures at the three main levels, and outdoor temperatures.

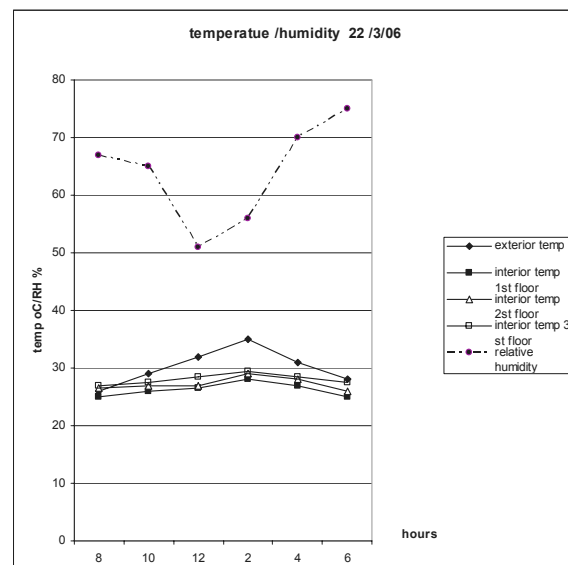

Figure 4: Temperature and humidity measurements

#### 4.1 Stratification air pattern

There is a difference between 1<sup>st</sup> and 3<sup>d</sup> floor of 3°C which remained stable during the monitoring period. The internal air speed was about 0.10 m/s due basically to convective forces.

#### 4.2 Diminution of maximum external temperatures.

The difference between external temperature and 3<sup>rd</sup> floor temperature increases significantly during mid day. A maximum reduction of 6 °C was obtained. In the other hand, at the end of the afternoon, internal air temperatures at the 3<sup>d</sup> floor are very close to the external temperatures ( 29 °C)

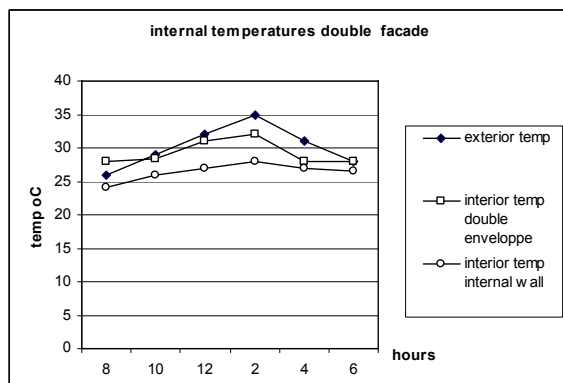

Figure 5: Temperature measurements west façade.

#### 4.3 The effect of the double façade.

Into the internal service corridor the temperature pattern repeats the atria pattern in comparison with the external temperature profile. This means a maximum difference at midday and minimum during the morning and at the end of the day. Stack effect is highly improved with air speeds between 0.1 m/seg and 0.30 m/s. Inside the shop commercial areas, the temperatures are lower and more stable than those observed at the double façade and atria plazas. See monitoring results at Fig 5 above. Figure 6 shows the construction process.

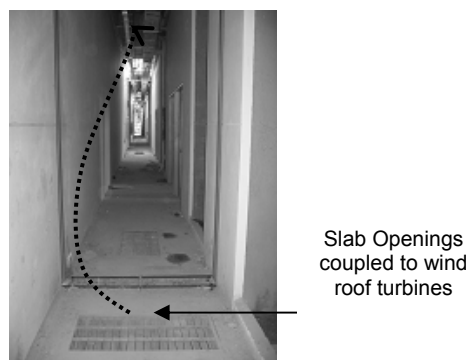

Figure 6: Internal view of double west façade.

## 5. CONCLUSIONS.

Preliminary results show that comfort could be achieved as a dynamic response from many cooling techniques integrated to the architecture. Table 1 shows test results.

Table 1: Preliminary comfort responses related to theoretical bioclimatic requirements.

comfort response - according to Givonni's bioclimatic chart [2]

hours	8	10	12	2	4	6
exterior temp	26	29	32	35	31	28
comfort - 1st floor	yes (2)	yes (2)	yes (2)	yes (1)	yes (1)	yes (2)
comfort - 2nd floor	yes (2)	yes (1)	yes (2)	yes (1)	yes (1)	yes (2)
comfort - 3 <sup>d</sup> floor	yes (2)	yes (1)	yes (1)	yes (1)	yes (1)	yes (1)
relative humidity	67	65	51	56	70	75

(1) with minimum continuous ventilation flow : 0.10-0.50 m/sec [3]

(2). without ventilation

- The building response at this construction stage is according to the technical report held during the design process.
- The 1<sup>st</sup> and 2<sup>nd</sup> floors have a good performance according to bioclimatic requirements.
- In the case of the 3<sup>d</sup> floor, if the relative humidity rises up from 75%, especially in rainy days, ventilation air flow is essential to create a reasonable comfort level. To facilitate this, there are under construction 10 underground pipes units (10000 CFM each one), which are able to release the air at 26 °C ( measured temperature of underground concrete exchangers).
- The roof plays the main role to guarantee a good performance base on the following features:
  - The open exhaust area of the ventilate sky lights actuating as wind turbines according to the figure No 6 represents minimum 10% of the floor area. 14 units were installed on the top. Exhaust areas are designed to promote maximum heat release and temperature differences. ( see figures 7 and 8)
  - The total height of the atria is two times the effective user height ( 2.50 mts ) for the 1<sup>st</sup> and 2<sup>nd</sup> floor, and three times for the 3<sup>d</sup> floor (see figure 9 ).
  - 100% of the internal space is protected against solar direct radiation, during peak hours.
  - The ventilated skylight allows diffused lighting and avoids UV and IR portion, by placing opal polycarbonate sheets on the top of each tower.
  - The double ventilated façade is essential to compensate the effect of the mass inertia of the concrete structure and brick massive walls.



**Figure 7 :** Ventilated sky lights.

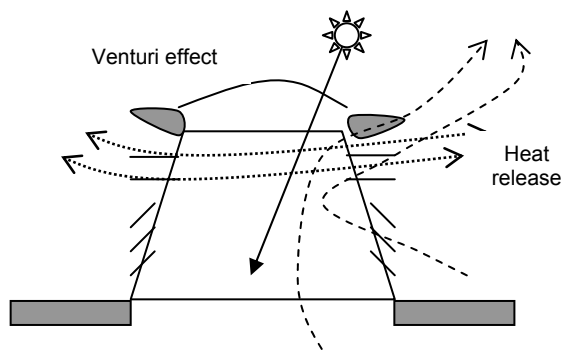

**Figure 8 :** Sky light operation



**Figure 9:** Main atrium space finished by June

## 6. FINAL COMMENTS

Sustainable tropical architecture leads with many factors, which encourages strategic but simple solutions. In this case the budget allowed to the project has a direct and mandatory relation to the commercial success. In many cases the commercial building promoter decides to use air conditioning systems, even if natural cooling systems are suitable as an initial and operative cost structure. This is a result of a cultural expectancy. In the Villavicencio commercial mall (see fig 10), the shop owners and the promoter tacked the decision to use natural cooling systems as a result of economical reasons and low expectancies regarding the customers profile.

Many technical specifications require to be reviewed in order to make possible and adequate cost structures. As an example, aluminium sky light blinds (imported) were changed to steel home made blinds. The roof insulation was defined initially as expanded polyethylene. The local available roof using mineral wool was finally decided even if the thermal conductivity is less increased.

Finally, it is important to comment that high tech cooling strategies, in many times are not the best alternative under the developing countries context. Consequently, naturally cooling techniques could be effective and economically achieved if some criterion are regarded:

- The use of a combined horizontal/vertical air flow pattern is strongly encouraged.[4]
- If a light weight building (suitable for hot humid climates) is not possible, and a massive building is designed. Roofs and walls must be carefully designed as double ventilated envelope. This promotes radiant heat release and lower insulation costs.
- Complexity in the general plan, as a result of architectural needs, could be managed if the space's thermal balance is divided separately in "typical thermal areas". This because, heat transfer patterns changes depending on the level floor, volume, area or occupancy pattern (corridor, café terrace, service areas etc).
- Shading devices are encouraged using simple solutions as Venetian blinds, or cantilevered sun grids. Is not recommended for sun control the use of complex volumes. In this case facades and openings could be placed at the same plane, in order to allow incoming breezes to come into the building. This is illustrated by the figure 11 and figure 12.

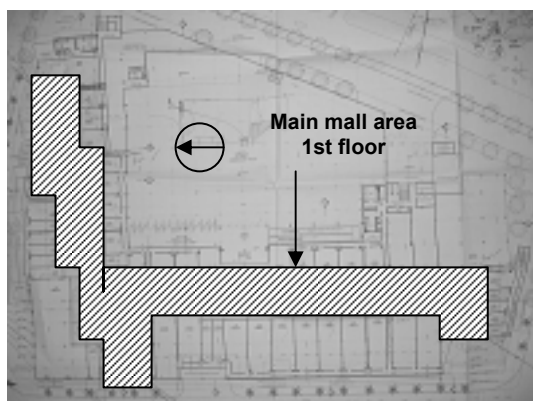

Figure 10: Commercial plan 1<sup>st</sup> floor

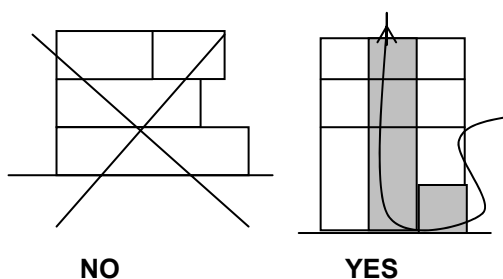

Figure 11: Recommended building shapes



Figure 12: Sun screen east facade

## REFERENCES

- [1] R.M Aynsley, Tropical housing comfort by natural airflow, Batiment International Building research and Practice, Vol 8, No 4, July/August (1980)
- [2] B. Givoni, Homme L'Architecture et le Climat, Ed du Moniteur, Paris (1978)
- [3] A. Adarve, Le role des énergies naturelles dans la rehabilitation de l'habitat rural en Colombie, These de maitrise, U. de Montreal, (1981)
- [4] A. Adarve, Improvements on passive Ventilation: A World Wide Design Tool and Architectural mechanisms to ensure comfort in equatorial tropical areas, Proc. PLEA 99 conference, Brisbane, (1999)

## ACKNOWLEDGEMENTS

This project was possible as a result of the effort leaded by the promoter PREDRO GOMEZ Y CIA, a colombian recognized urban developer. The responsible architect is OSCAR NOVOA senior architect of PINTO Y GOMEZ ASSOCIATES.

The commercial centre was completed by June 2006, after one year of building works.